

BLDG # 1  
 Style (Tb-02) 1.0 One Story  
 Quality (Yr-95) B B-Above Ave  
 Building Use 0040 Single Fami  
 Exterior Wall 1 M Masonry  
 Exterior Wall 2  
 Foundation Adj F Full Bsmt  
 Basement  
 Combination  
 Attic Area  
 Heat/AC Adj AC Central Air  
 Comb Ht/AC Adj  
 Fireplace 02 B-Fireplace  
 Extra Fireplace 00 N/A  
 Res Fixtures 0011 11 Fixtures  
 Garage M Garage Attd  
 Mobile Home 0000 N/A  
 Design Adj 00 N/A  
 Actual Year Blt 2016  
 Effect Year Blt 2016  
 Normal Depr Tbl A Res CDU - A  
 Functional Obs. 000000  
 Economic Obs. 000000  
 Observed Cond. 000000  
 Obs. Cond. Code  
 Cost Factor 000 N/A

MILLSTADT IL 62260  
 Site Address: 006609 AUGGIES WAY PL

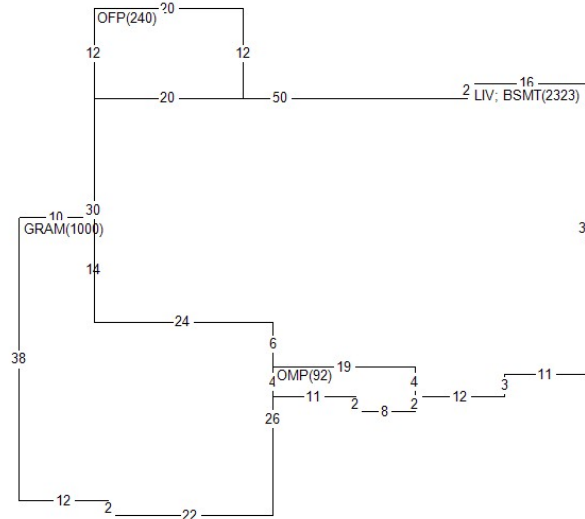

BOOK	PAGE	DATE	QS	SALE PRICE
		1215	U	35,000
		0814	U	35,000

PERMIT NO	TYPE	DATE	AMOUNT
201600993	NC	0416	40,000
201503332	RS	1115	275,000

Appraiser 046 DG  
 Apr Date 05/02/25  
 Use Code 0040 Imp. Res.  
 NBHD 220002.00 Millstadt  
 L105 M105 B105

AREA	FLAT	EFF% E/AREA	ACT% A/AREA	EA/AA HEATED
GRAM	1000	1.00	1000	1000
LIV	2323	1.00	2323	2323 2323
BSMT	2323	1.00	2323	2323 2323
OFFP	240	1.00	240	240 240
OMP	92	1.00	92	92 92

History Values

Tax Year	Total Appraised Value
24	433,394
23	393,921
22	358,860

MISC BLDG CODE	DESC	LENGTH	WIDTH	UNITS	EYB DT
1 1 PLCP	Pool Concrete	.00	.00	864.00	2016 A
2 1 OMP	Open Msnry Porch	.00	.00	92.00	2016 G
3 1 CP	Concrete Paving	24.00	3.00	72.00	2016 A
4 1 CP	Concrete Paving	.00	.00	1384.00	2016 A
6 1 OFFP	Open Frame Porch	20.00	12.00	240.00	2016 G
7 1 FV4R60	FENCE VYNL 4 RAI	.00	.00	325.00	2016 A

LAND LUSE DESC	UNITS TP	ADJUSTMENT CODES
1 0040 RES- IMP RESIDEN	1.00 L	

Req By: ANDREA 02/27/26 5:55:33 ST CLAIR CURRENT YEAR 2025  
GOSHEN WILLIAM R JR & BARBARA  
6609 AUGGIES WAY PL

MILLSTADT IL 62260  
Site Address: 006609 AUGGIES WAY PL

BOOK PAGE DATE QS SALE PRICE

PERMIT NO TYPE DATE AMOUNT

Appraiser 046 DG  
Appr Date 05/02/25  
Use Code 0040 Imp. Res.  
NBHD 220002.00 L105 M105 B105

History Values

Tax Year	Total Appraised Value
21	331,818
20	340,560
19	326,613

MISC	BLDG CODE	DESC	LENGTH	WIDTH	UNITS	EYB DT
9	1 CP	Concrete Paving	37.00	4.00	148.00	2016 A
10	1 VCL	Vaulted Ceiling	.00	.00	260.00	2005 G
11	1 FB	Finished Basemen	.00	.00	1200.00	2016 G