

Req By: ANDREA  
MCDADE WILLIAM  
6671 BEIL RD

02/27/26 5:55:33 ST CLAIR CURRENT YEAR 2025  
CHELLE

MILLSTADT IL 62260

Site Address: 006671 BEIL RD

BLDG # 1  
 Style (Tb-02) 1.0 One Story  
 Quality (Yr-95) B B-Above Ave  
 Building Use 0040 Single Fami  
 Exterior Wall 1 M75 75% Masonry  
 Exterior Wall 2 F25 25% Frame  
 Foundation Adj F Full Bsmt  
 Basement  
 Combination  
 Attic Area  
 Heat/AC Adj AC Central Air  
 Comb Ht/AC Adj  
 Fireplace 02 B-Fireplace  
 Extra Fireplace 00 N/A  
 Res Fixtures 0010 10 Fixtures  
 Garage MF Masonry/Fra  
 Mobile Home 0000 N/A  
 Design Adj 00 N/A  
 Actual Year Blt 2011  
 Effect Year Blt 2011  
 Normal Depr Tbl A Res CDU - A  
 Functional Obs. 000000  
 Economic Obs. 000000  
 Observed Cond. 000000  
 Obs. Cond. Code  
 Cost Factor 000 N/A

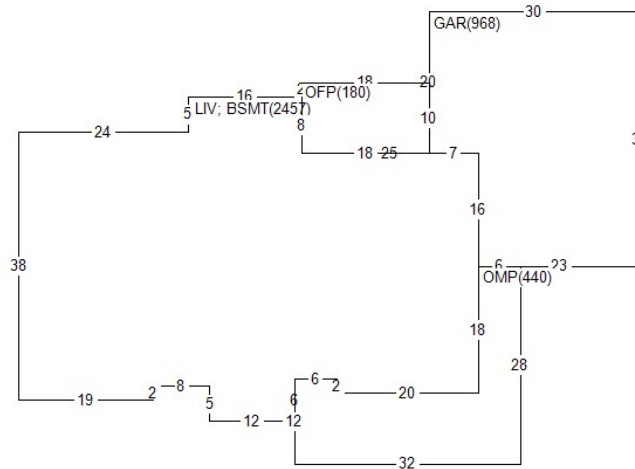

BOOK	PAGE	DATE	QS	SALE PRICE
		0623	U	28,500

PERMIT NO	TYPE	DATE	AMOUNT

Appraiser 046 DG  
 Apr Date 05/02/25  
 Use Code 0040 Imp. Res.  
 NBHD 220002.00 Millstadt  
 L105 M105 B105

AREA	FLAT	EFF% E/AREA	ACT% A/AREA	EA/AA	HEATED
LIV	2457	1.00	2457	1.00	2457
BSMT	2457	1.00	2457	1.00	2457
GAR	968	1.00	968	1.00	968
OMP	440	1.00	440	1.00	440
OFF	180	1.00	180	1.00	180

History Values

Tax Year	Total Appraised Value
24	467,464
23	424,896
22	387,078

MISC	BLDG CODE	DESC	LENGTH	WIDTH	UNITS	EYB DT	
1	1	OMP	Open Msnry Porch	.00	.00	440.00	2011 G
2	1	CP	Concrete Paving	168.00	13.00	2184.00	2011 A
4	1	OFF	Open Frame Porch	18.00	10.00	180.00	2011 G
5	1	CP	Concrete Paving	47.00	40.00	1880.00	2011 A
6	1	CP	Concrete Paving	86.00	6.00	516.00	2011 A
7	1	VCL	Vaulted Ceiling	.00	.00	1000.00	2005 G

LAND	LUSE	DESC	UNITS	TP	ADJUSTMENT CODES
1	0040	RES- IMP RESIDEN	1.00	L	

Req By: ANDREA  
MCDADE WILLIAM  
6671 BEIL RD

02/27/26 5:55:33 ST CLAIR CURRENT YEAR 2025  
CHELLE

MILLSTADT IL 62260  
Site Address: 006671 BEIL RD

BOOK PAGE DATE QS SALE PRICE

PERMIT NO TYPE DATE AMOUNT

Appraiser 046 DG  
Appr Date 05/02/25  
Use Code 0040 Imp. Res.  
NBHD 220002.00  
L105 M105 B105

History Values

Tax Year	Total Appraised Value
21	357,906
20	364,530
19	349,602

MISC	BLDG CODE	DESC	LENGTH	WIDTH	UNITS	EYB DT
8	1 FB	Finished Basemen	.00	.00	1250.00	2011 G