

BLDG # 1
 Style (Tb-02) 1.0 One Story
 Quality (Yr-95) B B-Above Ave
 Building Use 0040 Single Fami
 Exterior Wall 1 M75 75% Masonry
 Exterior Wall 2 F25 25% Frame
 Foundation Adj F Full Bsmt
 Basement
 Combination
 Attic Area
 Heat/AC Adj AC Central Air
 Comb Ht/AC Adj
 Fireplace 00 N/A
 Extra Fireplace 00 N/A
 Res Fixtures 0011 11 Fixtures
 Garage M Garage Attd
 Mobile Home 0000 N/A
 Design Adj 07 N/A
 Actual Year Blt 2006
 Effect Year Blt 2006
 Normal Depr Tbl A Res CDU - A
 Functional Obs. 000000
 Economic Obs. 000000
 Observed Cond. 000000
 Obs. Cond. Code
 Cost Factor 000 N/A

MILLSTADT IL 622602209
 Site Address: 006691 BEIL RD

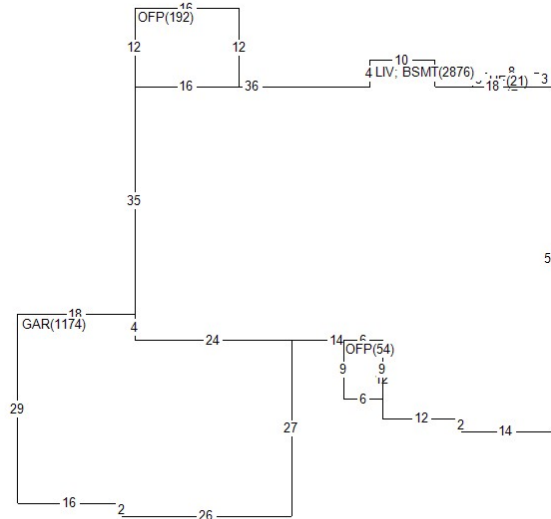

BOOK PAGE DATE QS SALE PRICE

PERMIT NO TYPE DATE AMOUNT
 1455 NC 0307 34,500
 1427 RS 0906 230,000

Appraiser 046 DG
 Apr Date 05/02/25
 Use Code 0040 Imp. Res.
 NBHD 220002.00 Millstadt
 L105 M105 B105

AREA	FLAT	EFF%	E/AREA	ACT%	A/AREA	EA/AA	HEATED
GAR	1174	1.00	1174	1.00	1174	1174	
UF	21	1.00	21	1.00	21	21	21
LIV	2876	1.00	2876	1.00	2876	2876	2876
BSMT	2876	1.00	2876	1.00	2876	2876	
OFF	246	1.00	246	1.00	246	246	

History Values

Tax Year	Total Appraised Value
24	512,306
23	465,648
22	424,203

MISC	BLDG CODE	DESC	LENGTH	WIDTH	UNITS	EYB	DT
1	1 OMP	Open Msnry Porch	6.00	9.00	54.00	2006	G
5	1 OFP	Open Frame Porch	12.00	16.00	192.00	2006	G
6	1 CP	Concrete Paving	87.00	15.00	1305.00	2006	A
7	1 CP	Concrete Paving	30.00	36.00	1080.00	2006	A
8	1 PLCP	Pool Concrete	5.00	120.00	600.00	2008	A
9	1 FV6'SB	FENCE VYNL 6' SL	.00	.00	160.00	2006	A

LAND	LUSE	DESC	UNITS	TP	ADJUSTMENT CODES
1	0040	RES- IMP RESIDEN	1.00	L	

Req By: ANDREA 02/27/26 5:55:33 ST CLAIR CURRENT YEAR 2025
KNOBELOCH WILLIAM SR & SUSAN M
6691 BEIL RD

MILLSTADT IL 622602209
Site Address: 006691 BEIL RD

BOOK PAGE DATE QS SALE PRICE

PERMIT NO TYPE DATE AMOUNT

Appraiser 046 DG
Appr Date 05/02/25
Use Code 0040 Imp. Res.
NBHD 220002.00 L105 M105 B105

History Values

Tax Year	Total Appraised Value
21	392,241
20	401,574
19	385,128

MISC	BLDG CODE	DESC	LENGTH	WIDTH	UNITS	EYB DT
10	1 CP	Concrete Paving	36.00	4.00	144.00	2006 A
11	1 VCL	Vaulted Ceiling	.00	.00	800.00	2005 G