

MASCOUTAH IL 62258
 Site Address: 000315 N JACKSON ST

BLDG # 1
 Style (Tb-02) 1.0 One Story
 Quality (Yr-95) C+5 C+5 Average
 Building Use 0040 Single Fami
 Exterior Wall 1 M Masonry
 Exterior Wall 2
 Foundation Adj F Full Bsmt
 Basement
 Combination
 Attic Area
 Heat/AC Adj AC Central Air
 Comb Ht/AC Adj
 Fireplace 03 C-Fireplace
 Extra Fireplace 00 N/A
 Res Fixtures 0005 05 Fixtures
 Garage M Garage Attd
 Mobile Home 0000 N/A
 Design Adj 00 N/A
 Actual Year Blt 1961
 Effect Year Blt 2000
 Normal Depr Tbl A Res CDU - A
 Functional Obs. 000000
 Economic Obs. 000000
 Observed Cond. 000000
 Obs. Cond. Code
 Cost Factor 000 N/A

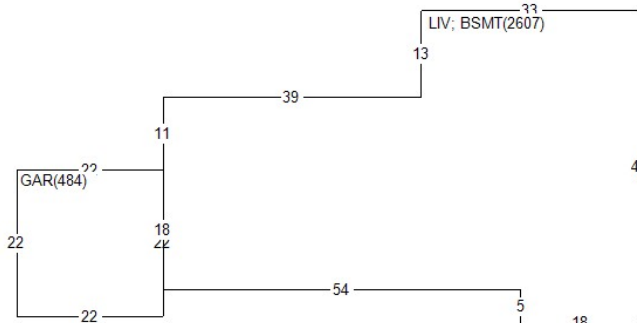

BOOK	PAGE	DATE	QS	SALE PRICE
		0423	Q	350,000
		0522	Q	340,000
		1219	Q	192,500
PERMIT NO	TYPE	DATE		AMOUNT

Appraiser 040 KK
 Apr Date 10/13/21
 Use Code 0040 Imp. Res.
 NBHD 30017.00 Mascoutah
 L100 M100 B125

AREA	FLAT	EFF% E/AREA	ACT% A/AREA	EA/AA HEATED
GAR	484	1.00	484 1.00	484 484
LIV	2607	1.00	2607 1.00	2607 2607 2607
BSMT	2607	1.00	2607 1.00	2607 2607

History Values

Tax Year	Total Appraised Value
24	321,579
23	293,892
22	267,468

MISC BLDG CODE	DESC	LENGTH	WIDTH	UNITS	EYB DT
1 1 EMP	Encl Msnry Porch	11.00	22.00	242.00	2000 A
2 1 CP	Concrete Paving	42.00	18.00	756.00	1961 A
3 1 CP	Concrete Paving	4.00	30.00	120.00	1961 A
4 1 PATIOCNC	Concrete Patio	41.00	12.00	492.00	1985 A
5 1 SHDF	Shed Dirt Floor	12.00	8.00	96.00	1985 A

LAND LUSE DESC	UNITS TP	ADJUSTMENT CODES
1 0040 RES- IMP RESIDEN	1.00 L	