

MASCOUTAH IL 62258

Site Address: 009723 WINCHESTER ST

BLDG # 1
 Style (Tb-02) 1.0 One Story
 Quality (Yr-95) B B-Above Ave
 Building Use 0040 Single Fami
 Exterior Wall 1 F75 75% Frame
 Exterior Wall 2 M25 25% Masonry
 Foundation Adj F Full Bsmt
 Basement
 Combination
 Attic Area
 Heat/AC Adj AC Central Air
 Comb Ht/AC Adj
 Fireplace 03 C-Fireplace
 Extra Fireplace 00 N/A
 Res Fixtures 0010 10 Fixtures
 Garage MF Masonry/Fra
 Mobile Home 0000 N/A
 Design Adj 04 Good
 Actual Year Blt 2014
 Effect Year Blt 2014
 Normal Depr Tbl A Res CDU - A
 Functional Obs. 000000
 Economic Obs. 000000
 Observed Cond. 000000
 Obs. Cond. Code
 Cost Factor 000 N/A

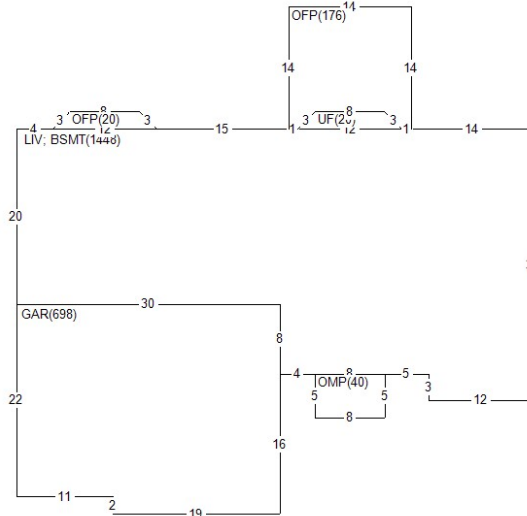

BOOK	PAGE	DATE	QS	SALE PRICE
		0115	Q	313,070
		1013	U	44,300

PERMIT NO	TYPE	DATE	AMOUNT
MAS16-42	NC	0816	35,000
13-49	RS	0913	180,000

Appraiser 033 JL
 Apr Date 08/11/21
 Use Code 0040 Imp. Res.
 NBHD 30010.00 Mascoutah
 L100 M115 B125

AREA	FLAT	EFF% E/AREA	ACT% A/AREA	EA/AA	HEATED
LIV	1448	1.00	1448	1.00	1448
BSMT	1448	1.00	1448	1.00	1448
GAR	698	1.00	698	1.00	698
OMP	40	1.00	40	1.00	40
OFP	196	1.00	196	1.00	196
UF	20	1.00	20	1.00	20

History Values

Tax Year	Total Appraised Value
24	400,757
23	366,258
22	333,324

MISC	BLDG CODE	DESC	LENGTH	WIDTH	UNITS	EYB DT
	1	OMP	8.00	5.00	40.00	2014 A
	2	OFP	14.00	14.00	196.00	2014 A
	3	CP	.00	.00	1072.00	2014 A
	4	CP	23.00	3.00	69.00	2014 A
	5	FV6'SB	.00	.00	240.00	2016 A
	6	CP	.00	.00	400.00	2017 A

LAND	LUSE	DESC	UNITS	TP	ADJUSTMENT CODES
1	0040	RES- IMP RESIDEN	1.00	L	

Req By: ANDREA 02/27/26 8:03:08 ST CLAIR CURRENT YEAR 2025
M HARRISON THOMAS & KI
9723 WINCHESTER ST

MASCOUTAH IL 62258
Site Address: 009723 WINCHESTER ST

BOOK PAGE DATE QS SALE PRICE

PERMIT NO TYPE DATE AMOUNT

Appraiser 033 JL
Appr Date 08/11/21
Use Code 0040 Imp. Res.
NBHD 30010.00 L100 M115 B125

History Values

Tax Year	Total Appraised Value
21	304,365
20	292,377
19	285,498

MISC	BLDG CODE	DESC	LENGTH	WIDTH	UNITS	EYB DT
7	1	FIN BASE	.00	.00	1232.00	2016 A
8	1 VCL	Vaulted Ceiling	.00	.00	800.00	2014 A