

MASCOUTAH IL 62258

Site Address: 000829 INDIAN PRAIRIE DR

BLDG # 1
 Style (Tb-02) 1.0 One Story
 Quality (Yr-95) C+10 C+10 Averag
 Building Use 0040 Single Fami
 Exterior Wall 1 F75 75% Frame
 Exterior Wall 2 M25 25% Masonry
 Foundation Adj F Full Bsmt
 Basement
 Combination
 Attic Area
 Heat/AC Adj AC Central Air
 Comb Ht/AC Adj
 Fireplace 03 C-Fireplace
 Extra Fireplace 00 N/A
 Res Fixtures 0010 10 Fixtures
 Garage MF Masonry/Fra
 Mobile Home 0000 N/A
 Design Adj 04 Good
 Actual Year Blt 2008
 Effect Year Blt 2008
 Normal Depr Tbl A Res CDU - A
 Functional Obs. 000000
 Economic Obs. 000000
 Observed Cond. 000000
 Obs. Cond. Code
 Cost Factor 000 N/A

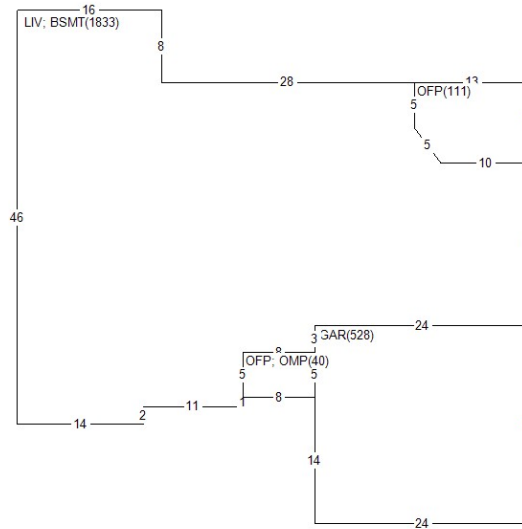

BOOK	PAGE	DATE	QS	SALE PRICE
		0519	Q	257,000

PERMIT NO	TYPE	DATE	AMOUNT
MAS 09-07	RS	0109	150,000

Appraiser 033 JL
 Apr Date 08/10/21
 Use Code 0040 Imp. Res.

AREA	FLAT	EFF% E/AREA	ACT% A/AREA	EA/AA	HEATED	NBHD	30010.00	Mascoutah
GAR	528	1.00	528	1.00	528	528		
LIV	1833	1.00	1833	1.00	1833	1833	1833	
BSMT	1833	1.00	1833	1.00	1833	1833		
OFFP	151	1.00	151	1.00	151	151		
OMP	40	1.00	40	1.00	40	40		

History Values

Tax Year	Total Appraised Value
24	324,768
23	296,808
22	270,120

MISC	BLDG CODE	DESC	LENGTH	WIDTH	UNITS	EYB DT
1	1 CP	Concrete Paving	34.00	18.00	612.00	2008 A
2	1 OMP	Open Msnry Porch	8.00	5.00	40.00	2008 A
3	1 OFFP	Open Frame Porch	.00	.00	111.00	2008 A
4	1 CP	Concrete Paving	24.00	3.00	72.00	2008 A
5	1 CP	Concrete Paving	52.00	2.00	104.00	2008 A

LAND	LUSE	DESC	UNITS	TP	ADJUSTMENT CODES
1	0040	RES- IMP RESIDEN	1.00	L	