

BLDG # 1
Style (Tb-02) 1.0 One Story
Quality (Yr-95) C+10 C+10 Averag
Building Use 0040 Single Fami
Exterior Wall 1 F Frame
Exterior Wall 2
Foundation Adj F Full Bsmt
Basement
Combination
Attic Area
Heat/AC Adj AC Central Air
Comb Ht/AC Adj
Fireplace 03 C-Fireplace
Extra Fireplace 00 N/A
Res Fixtures 0010 10 Fixtures
Garage MF Masonry/Fra
Mobile Home 0000 N/A
Design Adj 04 Good
Actual Year Blt 2009
Effect Year Blt 2009
Normal Depr Tbl A Res CDU - A
Functional Obs. 000000
Economic Obs. 000000
Observed Cond. 000000
Obs. Cond. Code
Cost Factor 000 N/A

MASCOUTAH IL 62258
Site Address: 000917 INDIAN PRAIRIE DR

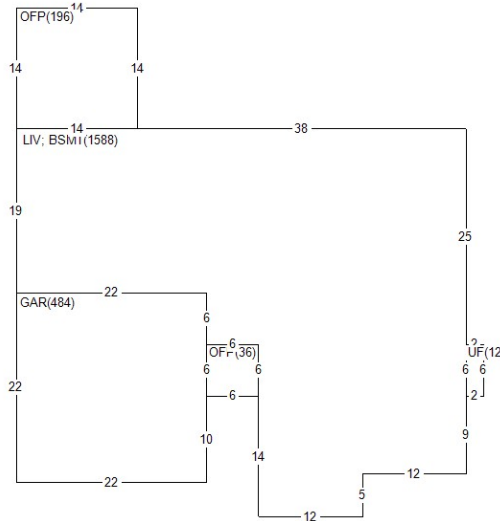

BOOK PAGE DATE QS SALE PRICE
0119 Q 227,500

PERMIT NO TYPE DATE AMOUNT
MAS16-36 NC 0716 9,233
MAS09-02 RS 0109 150,000

Appraiser 033 JL
Apr Date 08/09/21
Use Code 0040 Imp. Res.
NBHD 30010.00 Mascoutah
L100 M115 B125

AREA	FLAT	EFF% E/AREA	ACT% A/AREA	EA/AA	HEATED
OFFP	232	1.00	232	1.00	232
LIV	1588	1.00	1588	1.00	1588
BSMT	1588	1.00	1588	1.00	1588
GAR	484	1.00	484	1.00	484
UF	12	1.00	12	1.00	12

History Values

Tax Year	Total Appraised Value
24	349,372
23	319,296
22	290,586

MISC	BLDG CODE	DESC	LENGTH	WIDTH	UNITS	EYB DT
1	1	OFFP	6.00	6.00	36.00	2009 A
2	1	TMBC	.00	.00	246.00	2009 A
3	1	CP	.00	.00	2232.00	2009 A
4	1	CP	15.00	6.00	90.00	2009 A
5	1	OFFP	14.00	14.00	196.00	2017 A
6	1	SHDF	16.00	12.00	192.00	2017 A

LAND LUSE	DESC	UNITS	TP	ADJUSTMENT CODES
1	0040 RES- IMP RESIDEN	1.00	L	

Req By: ANDREA 02/27/26 8:03:08 ST CLAIR CURRENT YEAR 2025
A STAHL JASON & SABRIN
917 INDIAN PRAIRIE DR

MASCOUTAH IL 62258
Site Address: 000917 INDIAN PRAIRIE DR

BOOK PAGE DATE QS SALE PRICE

PERMIT NO TYPE DATE AMOUNT

Appraiser 033 JL
Appr Date 08/09/21
Use Code 0040 Imp. Res.
NBHD 30010.00 L100 M115 B125

History Values

Tax Year	Total Appraised Value
21	268,752
20	258,171
19	252,093

MISC	BLDG CODE	DESC	LENGTH	WIDTH	UNITS	EYB DT
7	1 FV6'SB	FENCE VYNL 6' SL	.00	.00	260.00	2017 A
8	1 VCL	Vaulted Ceiling	.00	.00	200.00	2009 A
9	1	FN BST	.00	.00	800.00	2016 A