

MASCOUTAH IL 622581637
 Site Address: 000905 CHICKASAW CT

BLDG # 1
 Style (Tb-02) 1.0 One Story
 Quality (Yr-95) C+10 C+10 Averag
 Building Use 0040 Single Fami
 Exterior Wall 1 F75 75% Frame
 Exterior Wall 2 M25 25% Masonry
 Foundation Adj F Full Bsmt
 Basement
 Combination
 Attic Area
 Heat/AC Adj AC Central Air
 Comb Ht/AC Adj
 Fireplace 03 C-Fireplace
 Extra Fireplace 00 N/A
 Res Fixtures 0010 10 Fixtures
 Garage F Garage Attd
 Mobile Home 0000 N/A
 Design Adj 00 N/A
 Actual Year Blt 2010
 Effect Year Blt 2010
 Normal Depr Tbl A
 Functional Obs. 000000
 Economic Obs. 000000
 Observed Cond. 000000
 Obs. Cond. Code
 Cost Factor 000 N/A

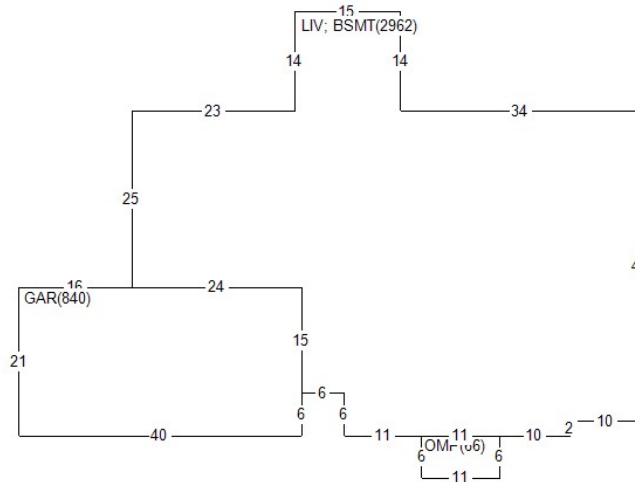

BOOK	PAGE	DATE	QS	SALE PRICE
------	------	------	----	------------

PERMIT NO	TYPE	DATE	AMOUNT
MAS 14-21	NC	0414	30,000
MAS10-74	RS	0710	287,297

Appraiser 033 JL
 Apr Date 08/06/21
 Use Code 0040 Imp. Res.
 NBHD 30010.00 Mascoutah
 L100 M115 B125

AREA	FLAT	EFF% E/AREA	ACT% A/AREA	EA/AA	HEATED
GAR	840	1.00	840	1.00	840
OMP	66	1.00	66	1.00	66
LIV	2962	1.00	2962	1.00	2962
BSMT	2962	1.00	2962	1.00	2962

History Values

Tax Year	Total Appraised Value
24	502,621
23	459,351
22	418,050

MISC	BLDG CODE	DESC	LENGTH	WIDTH	UNITS	EYB DT
1	1 CP	Concrete Paving	13.00	23.00	299.00	2011 A
2	1 CP	Concrete Paving	.00	.00	1250.00	2011 A
3	1	bsmt rec	.00	.00	1500.00	2011 A
4	1 OMP	Open Msnry Porch	6.00	10.00	60.00	2010 A
5	1 CP	Concrete Paving	31.00	13.00	403.00	2010 A
6	1 FV6'SB	FENCE VYNL 6' SL	.00	.00	340.00	2010 A

LAND LUSE DESC UNITS TP ----- ADJUSTMENT CODES -----

1 0040 RES- IMP RESIDEN 1.00 L

Req By: ANDREA 02/27/26 8:03:08 ST CLAIR CURRENT YEAR 2025
LAJOYE MICHAEL & KIM
905 CHICKASAW CT

MASCOUTAH IL 622581637
Site Address: 000905 CHICKASAW CT

BOOK PAGE DATE QS SALE PRICE

PERMIT NO TYPE DATE AMOUNT

Appraiser 033 JL
Appr Date 08/06/21
Use Code 0040 Imp. Res.
NBHD 30010.00 L100 M115 B125

History Values

Tax Year	Total Appraised Value
21	413,634
20	397,344
19	387,993

MISC	BLDG CODE	DESC	LENGTH	WIDTH	UNITS	EYB DT
7	1 CP	Concrete Paving	31.00	4.00	124.00	2010 A
8	1 SHDF	Shed Dirt Floor	12.00	8.00	96.00	2010 A
9	1 PTOC	Patio Concrete	.00	.00	1115.00	2014 A