

Req By: ANDREA BAKER JESSICA
REGIONS BANK TRUSTEE
PO BOX 13519

02/27/26 8:03:08 ST CLAIR CURRENT YEAR 2025

ARLINGTON TX 76094

Site Address: 009717 WINNEBAGO WA

BLDG # 1
Style (Tb-02) 1.0 One Story
Quality (Yr-95) B-5 B-5 Above A
Building Use 0040 Single Fami
Exterior Wall 1 F75 75% Frame
Exterior Wall 2 M25 25% Masonry
Foundation Adj F Full Bsmt
Basement
Combination
Attic Area
Heat/AC Adj AC Central Air
Comb Ht/AC Adj
Fireplace 02 B-Fireplace
Extra Fireplace 00 N/A
Res Fixtures 0013 13 Fixtures
Garage MF Masonry/Fra
Mobile Home 0000 N/A
Design Adj 00 N/A
Actual Year Blt 2016
Effect Year Blt 2016
Normal Depr Tbl A Res CDU - A
Functional Obs. 000000
Economic Obs. 000000
Observed Cond. 000000
Obs. Cond. Code
Cost Factor 000 N/A

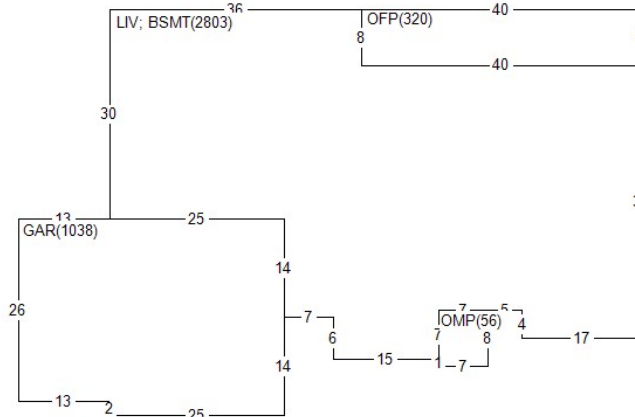

BOOK PAGE DATE QS SALE PRICE
0715 U 60,125

PERMIT NO TYPE DATE AMOUNT
MAS15-39 RS 0815 200,000
MAS15-39 RS 0815 200,000

Appraiser 033 JL
Apr Date 08/16/21
Use Code 0040 Imp. Res.

AREA	FLAT	EFF% E/AREA	ACT% A/AREA	EA/AA	HEATED
LIV	2803	1.00	2803	1.00	2803
BSMT	2803	1.00	2803	1.00	2803
OFP	320	1.00	320	1.00	320
OMP	56	1.00	56	1.00	56
GAR	1038	1.00	1038	1.00	1038

NBHD 30010.00 Mascoutah
L100 M115 B125

History Values

Tax Year	Total Appraised Value
24	554,917
23	507,144
22	461,544

MISC	BLDG CODE	DESC	LENGTH	WIDTH	UNITS	EYB DT	
1	1	PTOC	Patio Concrete	.00	.00	680.00	2016 A
2	1	OMP	Open Msnry Porch	8.00	7.00	56.00	2016 A
3	1	OFP	Open Frame Porch	40.00	8.00	320.00	2016 A
4	1	CP	Concrete Paving	134.00	4.00	536.00	2016 A
5	1	CP	Concrete Paving	39.00	3.00	117.00	2016 A
6	1	CP	Concrete Paving	.00	.00	1448.00	2016 A

LAND	LUSE	DESC	UNITS	TP	ADJUSTMENT CODES
1	0040	RES- IMP RESIDEN	1.00	L	

Req By: ANDREA 02/27/26 8:03:08 ST CLAIR CURRENT YEAR 2025
BAKER JESSICA
REGIONS BANK TRUSTEE
PO BOX 13519

ARLINGTON TX 76094
Site Address: 009717 WINNEBAGO WA

BOOK PAGE DATE QS SALE PRICE

PERMIT NO TYPE DATE AMOUNT

Appraiser 033 JL
Appr Date 08/16/21
Use Code 0040 Imp. Res.
NBHD 30010.00 L100 M115 B125

History Values

Tax Year	Total Appraised Value
21	452,952
20	435,111
19	424,872

MISC	BLDG CODE	DESC	LENGTH	WIDTH	UNITS	EYB DT
7	1	fin bsmt REC	.00	.00	2075.25	2016 A
8	1 CP	Concrete Paving	22.00	3.00	66.00	2016 A