

MASCOUTAH IL 62258

Site Address: 001007 WYANDOT CT

BLDG # 1  
 Style (Tb-02) 1.0 One Story  
 Quality (Yr-95) C+10 C+10 Averag  
 Building Use 0040 Single Fami  
 Exterior Wall 1 F75 75% Frame  
 Exterior Wall 2 M25 25% Masonry  
 Foundation Adj F Full Bsmt  
 Basement  
 Combination  
 Attic Area  
 Heat/AC Adj AC Central Air  
 Comb Ht/AC Adj  
 Fireplace 00 N/A  
 Extra Fireplace 00 N/A  
 Res Fixtures 0010 10 Fixtures  
 Garage F Garage Attd  
 Mobile Home 0000 N/A  
 Design Adj 04 Good  
 Actual Year Blt 2010  
 Effect Year Blt 2010  
 Normal Depr Tbl A Res CDU - A  
 Functional Obs. 000000  
 Economic Obs. 000000  
 Observed Cond. 000000  
 Obs. Cond. Code  
 Cost Factor 000 N/A

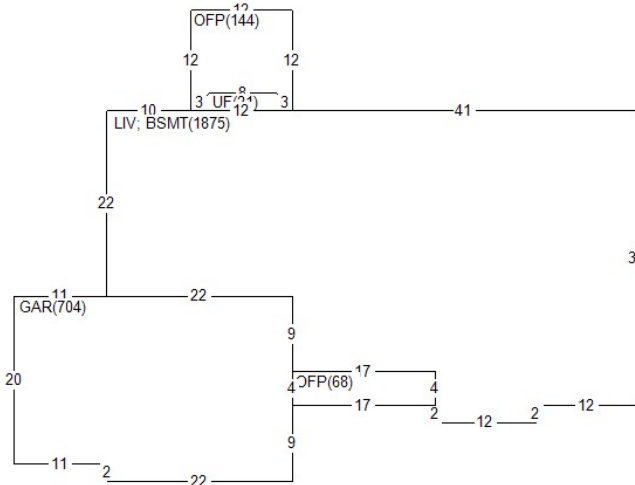

BOOK	PAGE	DATE	QS	SALE PRICE
		0715	Q	294,000

PERMIT NO	TYPE	DATE	AMOUNT
MAS.21.041	NC	0521	40,000
MAS09-77	RS	0809	150,000

Appraiser 033 JL  
 Apr Date 08/16/21  
 Use Code 0040 Imp. Res.

AREA	FLAT	EFF% E/AREA	ACT% A/AREA	EA/AA	HEATED
LIV	1875	1.00	1875	1.00	1875
BSMT	1875	1.00	1875	1.00	1875
OFP	212	1.00	212	1.00	212
GAR	704	1.00	704	1.00	704
UF	21	1.00	21	1.00	21

NBHD 30010.00 Mascoutah  
 L100 M115 B125

History Values

Tax Year	Total Appraised Value
24	408,530
23	373,362
22	339,789

MISC	BLDG CODE	DESC	LENGTH	WIDTH	UNITS	EYB DT
1	1	OFP	.00	.00	68.00	2010 A
3	1	OFP	.00	.00	144.00	2010 A
4	1	CP	.00	.00	1040.00	2010 A
5	1	CP	.00	.00	1100.00	2021 A
6	1	CP	28.00	3.00	84.00	2010 A
7	1	FV6'SB	.00	.00	403.00	00 A

LAND	LUSE	DESC	UNITS	TP	ADJUSTMENT CODES
1	0040	RES- IMP RESIDEN	1.00	L	

Req By: ANDREA 02/27/26 8:03:08 ST CLAIR CURRENT YEAR 2025  
D R CAHILL LISA N & DAVI  
1007 WYANDOT CT

MASCOUTAH IL 62258  
Site Address: 001007 WYANDOT CT

BOOK PAGE DATE QS SALE PRICE

PERMIT NO TYPE DATE AMOUNT

Appraiser 033 JL  
Appr Date 08/16/21  
Use Code 0040 Imp. Res.  
NBHD 30010.00 L100 M115 B125

History Values

Tax Year	Total Appraised Value
21	332,034
20	318,957
19	311,451

MISC	BLDG CODE	DESC	LENGTH	WIDTH	UNITS	EYB DT
8	1	FIN BASE	.00	.00	1000.00	2010 A