

MASCOUTAH IL 62258

Site Address: 001012 INDIAN PRAIRIE DR

BLDG # 1  
 Style (Tb-02) 1.0 One Story  
 Quality (Yr-95) B B-Above Ave  
 Building Use 0040 Single Fami  
 Exterior Wall 1 F75 75% Frame  
 Exterior Wall 2 M25 25% Masonry  
 Foundation Adj F Full Bsmt  
 Basement  
 Combination  
 Attic Area  
 Heat/AC Adj AC Central Air  
 Comb Ht/AC Adj  
 Fireplace 02 B-Fireplace  
 Extra Fireplace 00 N/A  
 Res Fixtures 0011 11 Fixtures  
 Garage MF Masonry/Fra  
 Mobile Home 0000 N/A  
 Design Adj 00 N/A  
 Actual Year Blt 2022  
 Effect Year Blt 2022  
 Normal Depr Tbl G Res CDU - G  
 Functional Obs. 000000  
 Economic Obs. 000000  
 Observed Cond. 000000  
 Obs. Cond. Code  
 Cost Factor 120 120%

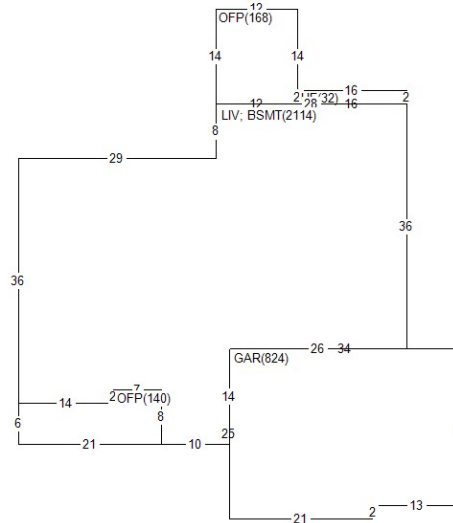

BOOK	PAGE	DATE	QS	SALE PRICE
		0323	Q	460,000
		0422	U	65,000
		1221	U	384,626
PERMIT NO	TYPE	DATE	AMOUNT	
MAS-21-079	RS	1221	450,000	

Appraiser 003 MJ  
 Apr Date 04/20/23  
 Use Code 0040 Imp. Res.  
 NBHD 30010.00 Mascoutah  
 L100 M115 B125

AREA	FLAT	EFF% E/AREA	ACT% A/AREA	EA/AA	HEATED
OFP	308	1.00	308	1.00	308
UF	32	1.00	32	1.00	32
GAR	824	1.00	824	1.00	824
LIV	2114	1.00	2114	1.00	2114
BSMT	2114	1.00	2114	1.00	2114

History Values

Tax Year	Total Appraised Value
24	486,783
23	374,835
22	58,908

MISC	BLDG CODE	DESC	LENGTH	WIDTH	UNITS	EYB DT
1	1 OFP	Open Frame Porch	.00	.00	134.00	2022 G
2	1 OFP	Open Frame Porch	12.00	14.00	168.00	2022 G
3	1 CP	Concrete Paving	31.00	37.00	1147.00	2022 A
4	1 CP	Concrete Paving	24.00	4.00	96.00	2022 A
5	1 FV6'SB	FENCE VYNL 6' SL	.00	.00	230.00	2022 A
6	1 VCL	Vaulted Ceiling	.00	.00	580.00	2022 G

LAND	LUSE	DESC	UNITS	TP	ADJUSTMENT CODES
1	0040	RES- IMP RESIDEN	1.00	L	

Req By: ANDREA 02/27/26 8:03:08 ST CLAIR CURRENT YEAR 2025  
RAH MUHAMMAD ALIM J & SA  
1012 INDIAN PRAIRIE DR

MASCOUTAH IL 62258  
Site Address: 001012 INDIAN PRAIRIE DR

BOOK PAGE DATE QS SALE PRICE

PERMIT NO TYPE DATE AMOUNT

Appraiser 003 MJ  
Appr Date 04/20/23  
Use Code 0040 Imp. Res.  
NBHD 30010.00 L100 M115 B125

History Values

Tax Year	Total Appraised Value
21	1,140
20	1,095
19	1,068

MISC BLDG CODE	DESC	LENGTH	WIDTH	UNITS	EYB DT
7 1 TMBC	Trim Mas/Brk CD-	.00	.00	80.00	2022 G