

BLDG # 1
 Style (Tb-02) 1.0 One Story
 Quality (Yr-95) B B-Above Ave
 Building Use 0040 Single Fami
 Exterior Wall 1 M25 25% Masonry
 Exterior Wall 2 F75 75% Frame
 Foundation Adj FB Full Bsmt
 Basement
 Combination
 Attic Area
 Heat/AC Adj AC Central Air
 Comb Ht/AC Adj
 Fireplace 02 B-Fireplace
 Extra Fireplace 00 N/A
 Res Fixtures 0013 13 Fixtures
 Garage MF Masonry/Fra
 Mobile Home 0000 N/A
 Design Adj 04 Good
 Actual Year Blt 2023
 Effect Year Blt 2023
 Normal Depr Tbl G Res CDU - G
 Functional Obs. 000000
 Economic Obs. 000000
 Observed Cond. 000000
 Obs. Cond. Code
 Cost Factor 120 120%

MASCOUTAH IL 62258
 Site Address: 009730 SENECA CT

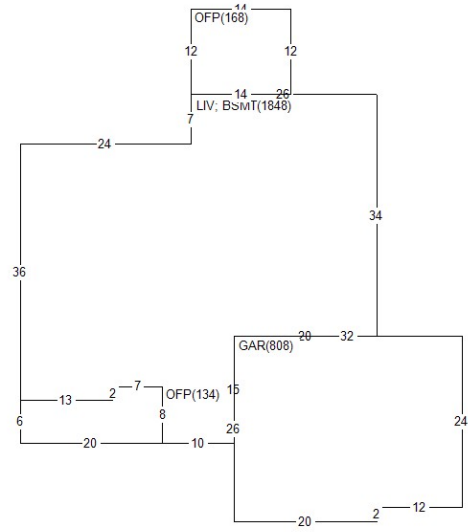

BOOK	PAGE	DATE	QS	SALE PRICE
		0923	Q	577,837
		0821	U	497,187

PERMIT NO	TYPE	DATE	AMOUNT
MAS-23-044	RS	0423	

Appraiser 039 JE
 Apr Date 03/18/24
 Use Code 0040 Imp. Res.
 NBHD 30010.00 Mascoutah
 L100 M115 B125

AREA	FLAT	EFF%	E/AREA	ACT%	A/AREA	EA/AA	HEATED
LIV	1848	1.00	1848	1.00	1848	1848	1848
BSMT	1848	1.00	1848	1.00	1848	1848	
GAR	808	1.00	808	1.00	808	808	
OFP	302	1.00	302	1.00	302	302	

History Values

Tax Year	Total Appraised Value
24	545,246
23	1,293
22	1,176

MISC	BLDG CODE	DESC	LENGTH	WIDTH	UNITS	EYB DT
	1	FB	.00	.00	1240.00	2023 G
	2	VCL	.00	.00	360.00	2023 G
	3	CP	65.00	32.00	2080.00	2023 A
	4	CP	28.00	4.00	112.00	2023 A
	5	OMP	.00	.00	134.00	2023 G
	6	OFP	14.00	12.00	168.00	2023 A

LAND	LUSE	DESC	UNITS	TP	ADJUSTMENT CODES
1	0040	RES- IMP RESIDEN	1.00	L	

Req By: ANDREA 02/27/26 8:03:08 ST CLAIR CURRENT YEAR 2025
MARCIE HANSON ANTHONY JR &
9730 SENECA CT

MASCOUTAH IL 62258
Site Address: 009730 SENECA CT

BOOK PAGE DATE QS SALE PRICE

PERMIT NO TYPE DATE AMOUNT

Appraiser 039 JE
Appr Date 03/18/24
Use Code 0040 Imp. Res.
NBHD 30010.00 L100 M115 B125

History Values

Tax Year	Total Appraised Value
21	1,140
20	1,095
19	1,068

MISC	BLDG CODE	DESC	LENGTH	WIDTH	UNITS	EYB DT
7	1 PTOC	Patio Concrete	12.00	12.00	144.00	2023 A
8	1 FV4R60	FENCE VYNL 4 RAI	.00	.00	72.00	2023 A