

MASCOUTAH IL 62258

Site Address: 001140 MENOMINEE TR

BLDG # 1  
 Style (Tb-02) 1.0 One Story  
 Quality (Yr-95) B-5 B-5 Above A  
 Building Use 0040 Single Fami  
 Exterior Wall 1 M25 25% Masonry  
 Exterior Wall 2 F75 75% Frame  
 Foundation Adj F Full Bsmt  
 Basement  
 Combination  
 Attic Area  
 Heat/AC Adj AC Central Air  
 Comb Ht/AC Adj  
 Fireplace 02 B-Fireplace  
 Extra Fireplace 00 N/A  
 Res Fixtures 0013 13 Fixtures  
 Garage MF Masonry/Fra  
 Mobile Home 0000 N/A  
 Design Adj 04 Good  
 Actual Year Blt 2023  
 Effect Year Blt 2023  
 Normal Depr Tbl A Res CDU - A  
 Functional Obs. 000000  
 Economic Obs. 000000  
 Observed Cond. 000000  
 Obs. Cond. Code  
 Cost Factor 120 120%

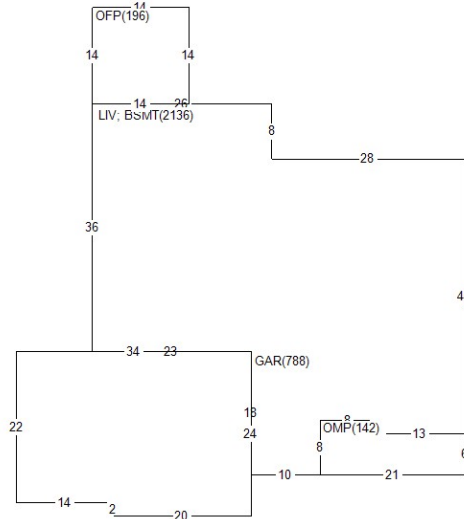

BOOK	PAGE	DATE	QS	SALE PRICE
		1223	Q	579,929
		0623	U	65,000
		0821	U	497,187
PERMIT NO	TYPE	DATE	AMOUNT	
MAS-23-058	RS	0523	250,000	

Appraiser 039 JE  
 Apr Date 03/20/24  
 Use Code 0040 Imp. Res.  
 NBHD 30010.00 Mascoutah  
 L100 M115 B125

AREA	FLAT	EFF%	E/AREA	ACT%	A/AREA	EA/AA	HEATED
LIV	2136	1.00	2136	1.00	2136	2136	2136
BSMT	2136	1.00	2136	1.00	2136	2136	
GAR	788	1.00	788	1.00	788	788	
OMP	142	1.00	142	1.00	142	142	
OFF	196	1.00	196	1.00	196	196	

History Values

Tax Year	Total Appraised Value
24	511,288
23	1,293
22	1,176

MISC	BLDG CODE	DESC	LENGTH	WIDTH	UNITS	EYB DT
	1	CP	35.00	32.00	1120.00	2023 A
	2	CP	30.00	4.00	120.00	2023 A
	3	OMP	.00	.00	142.00	2023 A
	4	OFF	14.00	14.00	196.00	2023 A
	5	FB	.00	.00	1068.00	2023 A
	6	FV6'SB	.00	.00	175.00	2023 A
		FENCE VYNL 6' SL				
LAND	LUSE	DESC	UNITS	TP	ADJUSTMENT CODES	
1	0040	RES- IMP RESIDEN	1.00	L		