

MASCOUTAH IL 62258

Site Address: 009655 WINNEBAGO WA

BLDG # 1
 Style (Tb-02) 1.0 One Story
 Quality (Yr-95) B B-Above Ave
 Building Use 0040 Single Fami
 Exterior Wall 1 M25 25% Masonry
 Exterior Wall 2 F75 75% Frame
 Foundation Adj F Full Bsmt
 Basement
 Combination
 Attic Area
 Heat/AC Adj AC Central Air
 Comb Ht/AC Adj
 Fireplace 00 N/A
 Extra Fireplace 00 N/A
 Res Fixtures 0011 11 Fixtures
 Garage MF Masonry/Fra
 Mobile Home 0000 N/A
 Design Adj 04 Good
 Actual Year Blt 2015
 Effect Year Blt 2015
 Normal Depr Tbl A Res CDU - A
 Functional Obs. 000000
 Economic Obs. 000000
 Observed Cond. 000000
 Obs. Cond. Code
 Cost Factor 000 N/A

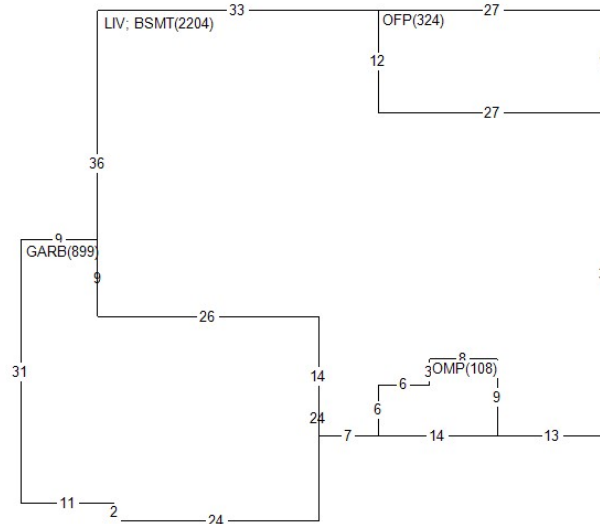

BOOK	PAGE	DATE	QS	SALE PRICE
		1015	Q	345,447
		0615	U	59,125

PERMIT NO	TYPE	DATE	AMOUNT
MAS 15-30	RS	0615	200,000

Appraiser 003 MJ
 Apr Date 08/06/21
 Use Code 0040 Imp. Res.
 NBHD 30010.00 Mascoutah
 L100 M115 B125

AREA	FLAT	EFF% E/AREA	ACT% A/AREA	EA/AA	HEATED
GARB	899	1.00	899	1.00	899
LIV	2204	1.00	2204	1.00	2204
BSMT	2204	1.00	2204	1.00	2204
OFFP	324	1.00	324	1.00	324
OMP	108	1.00	108	1.00	108

History Values

Tax Year	Total Appraised Value
24	336,950
23	336,951
22	306,654

MISC	BLDG CODE	DESC	LENGTH	WIDTH	UNITS	EYB DT	
	1	1 CP	Concrete Paving	.00	.00	1377.00	2015 A
	2	1 CP	Concrete Paving	4.00	4.00	16.00	2015 A
	3	1 CP	Concrete Paving	30.00	4.00	120.00	2015 A
	4	1 FV6'SB	FENCE VYNL 6' SL	.00	.00	163.00	2015 A
	5	1 OFFP	Open Frame Porch	.00	.00	324.00	2015 A
	6	1 OMP	Open Msnry Porch	.00	.00	108.00	2015 A

LAND LUSE DESC UNITS TP ----- ADJUSTMENT CODES -----

1	0040 RES- IMP RESIDEN	1.00	L
---	-----------------------	------	---

Req By: ANDREA 02/27/26 8:03:08 ST CLAIR CURRENT YEAR 2025
MICHAEL GRETZINGER ANGELA &
9655 WINNEBAGO WAY

MASCOUTAH IL 62258
Site Address: 009655 WINNEBAGO WA

BOOK PAGE DATE QS SALE PRICE

PERMIT NO TYPE DATE AMOUNT

Appraiser 003 MJ
Appr Date 08/06/21
Use Code 0040 Imp. Res.
NBHD 30010.00 L100 M115 B125

History Values

Tax Year	Total Appraised Value
21	334,305
20	321,138
19	313,581

MISC BLDG CODE	DESC	LENGTH	WIDTH	UNITS	EYB DT
7 1 CP	Concrete Paving	4.00	31.00	124.00	2015 A