

BLDG # 1
 Style (Tb-02) 2.0 2 Story
 Quality (Yr-95) B B-Above Ave
 Building Use 0040 Single Fami
 Exterior Wall 1 F Frame
 Exterior Wall 2
 Foundation Adj F Full Bsmt
 Basement
 Combination F1 Frame/1.0
 Attic Area
 Heat/AC Adj AC Central Air
 Comb Ht/AC Adj AC1 Cent AC Cmb
 Fireplace 02 B-Fireplace
 Extra Fireplace 00 N/A
 Res Fixtures 0013 13 Fixtures
 Garage MF Masonry/Fra
 Mobile Home 0000 N/A
 Design Adj 00 N/A
 Actual Year Blt 2016
 Effect Year Blt 2016
 Normal Depr Tbl A Res CDU - A
 Functional Obs. 000000
 Economic Obs. 000000
 Observed Cond. 000000
 Obs. Cond. Code
 Cost Factor 000 N/A

MASCOUTAH IL 62258
 Site Address: 009650 QUAPAW CT

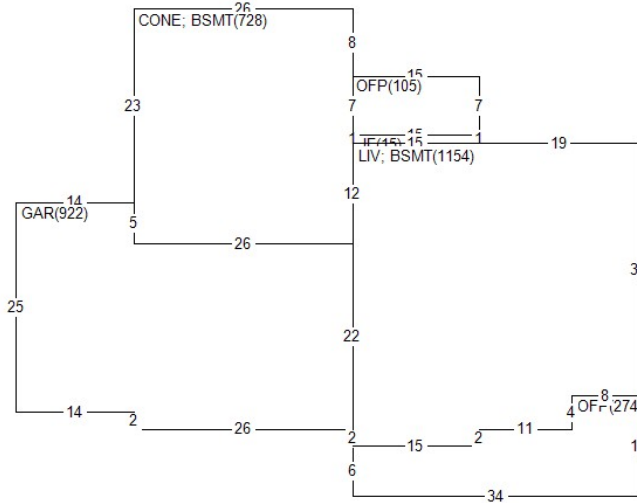

BOOK	PAGE	DATE	QS	SALE PRICE
		0217	Q	423,224
		0916	U	58,300

PERMIT NO	TYPE	DATE	AMOUNT
MAS17-01	NC	0117	11,000
MAS 16-49	RS	0916	400,000

Appraiser 003 MJ
 Apr Date 08/05/21
 Use Code 0040 Imp. Res.
 NBHD 30010.00 Mascoutah
 L100 M115 B125

AREA	FLAT	EFF% E/AREA	ACT% A/AREA	EA/AA	HEATED
OFP	379	1.00	379	1.00	379
UF	15	0.50	8	1.00	8
GAR	922	1.00	922	1.00	922
CONE	728	1.00	728	1.00	728
BSMT	1882	1.00	1882	1.00	1882
LIV	1154	1.00	1154	1.00	1154

History Values

Tax Year	Total Appraised Value
24	546,794
23	499,722
22	454,788

MISC	BLDG CODE	DESC	LENGTH	WIDTH	UNITS	EYB DT	
	1	CP	Concrete Paving	.00	.00	1765.00	2016 A
	2	CP	Concrete Paving	.00	.00	433.00	2016 A
	3	PATIOCNC	Concrete Patio	20.00	14.00	280.00	2016 A
	4	OFP	Open Frame Porch	.00	.00	274.00	2016 A
	5	OFP	Open Frame Porch	7.00	15.00	105.00	2016 A
	6	DECK	Deck - Wood	8.00	15.00	120.00	2016 A

LAND	LUSE	DESC	UNITS	TP	ADJUSTMENT CODES
1	0040	RES- IMP RESIDEN	1.00	L	

Req By: ANDREA 02/27/26 8:03:08 ST CLAIR CURRENT YEAR 2025
IZABETH WALTER NICHOLAS & EL
9650 QUAPAW CT

MASCOUTAH IL 62258
Site Address: 009650 QUAPAW CT

BOOK PAGE DATE QS SALE PRICE

PERMIT NO TYPE DATE AMOUNT

Appraiser 003 MJ
Appr Date 08/05/21
Use Code 0040 Imp. Res.
NBHD 30010.00 L100 M115 B125

History Values

Tax Year	Total Appraised Value
21	431,088
20	414,114
19	404,367

MISC	BLDG CODE	DESC	LENGTH	WIDTH	UNITS	EYB DT
7	1 TMBC	Trim Mas/Brk CD-	.00	.00	355.00	2016 A
8	1 FB	Finished Basemen	.00	.00	1000.00	2017 A