

Req By: ANDREA
BELKNAP CARL & LORI
9713 QUAPAW CT

MASCOUTAH IL 62258

Site Address: 009713 QUAPAW CT

BLDG # 1
 Style (Tb-02) 1.0 One Story
 Quality (Yr-95) C+10 C+10 Averag
 Building Use 0040 Single Fami
 Exterior Wall 1 M25 25% Masonry
 Exterior Wall 2 F75 75% Frame
 Foundation Adj F Full Bsmt
 Basement
 Combination
 Attic Area
 Heat/AC Adj AC Central Air
 Comb Ht/AC Adj
 Fireplace 03 C-Fireplace
 Extra Fireplace 00 N/A
 Res Fixtures 0011 11 Fixtures
 Garage MF Masonry/Fra
 Mobile Home 0000 N/A
 Design Adj 00 N/A
 Actual Year Blt 2017
 Effect Year Blt 2017
 Normal Depr Tbl A Res CDU - A
 Functional Obs. 000000
 Economic Obs. 000000
 Observed Cond. 000000
 Obs. Cond. Code
 Cost Factor 000 N/A

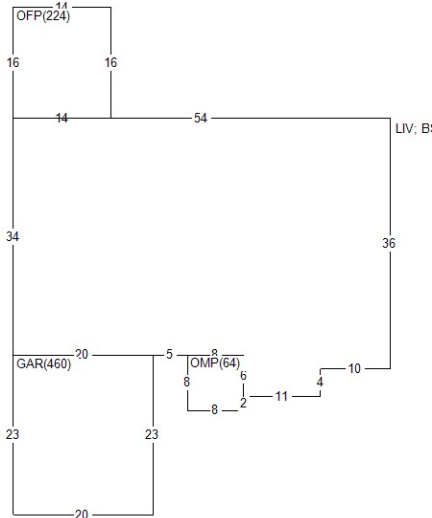

BOOK	PAGE	DATE	QS	SALE PRICE
		0419	Q	293,000
		0419	U	47,000

PERMIT NO	TYPE	DATE	AMOUNT
MAS 17-55	RS	0817	275,000

Appraiser 003 MJ
 Apr Date 08/05/21
 Use Code 0040 Imp. Res.

AREA	FLAT	EFF%	E/AREA	ACT%	A/AREA	EA/AA	HEATED	NBHD	30010.00	Mascoutah
OFP	224	1.00	224	1.00	224	224				
LIV	1922	1.00	1922	1.00	1922	1922	1922			
BSMT	1922	1.00	1922	1.00	1922	1922				
OMP	64	1.00	64	1.00	64	64				
GAR	460	1.00	460	1.00	460	460				

L100 M115 B125

History Values

Tax Year	Total Appraised Value
24	346,722
23	316,869
22	288,378

MISC	BLDG CODE	DESC	LENGTH	WIDTH	UNITS	EYB DT
1	1 CP	Concrete Paving	35.00	30.00	1050.00	2017 A
2	1 CP	Concrete Paving	27.00	4.00	108.00	2017 A
3	1 OMP	Open Msnry Porch	8.00	8.00	64.00	2017 A
4	1 OFP	Open Frame Porch	16.00	14.00	224.00	2017 A
5	1 VCL	Vaulted Ceiling	.00	.00	560.00	2017 A
6	1 FV4'SB	FENCE VYNL 4' SL	.00	.00	140.00	2019 A

LAND	LUSE	DESC	UNITS	TP	ADJUSTMENT CODES
1	0040	RES- IMP RESIDEN	1.00	L	