

BLDG # 1  
 Style (Tb-02) 2.0 2 Story  
 Quality (Yr-95) C+10 C+10 Averag  
 Building Use 0040 Single Fami  
 Exterior Wall 1 F Frame  
 Exterior Wall 2  
 Foundation Adj S Slab  
 Basement  
 Combination F1 Frame/1.0  
 Attic Area  
 Heat/AC Adj AC Central Air  
 Comb Ht/AC Adj AC1 Cent AC Cmb  
 Fireplace 03 C-Fireplace  
 Extra Fireplace 00 N/A  
 Res Fixtures 0015 15 Fixtures  
 Garage IG Integral Ga  
 Mobile Home 0000 N/A  
 Design Adj 04 Good  
 Actual Year Blt 2024  
 Effect Year Blt 2024  
 Normal Depr Tbl A Res CDU - A  
 Functional Obs. 000000  
 Economic Obs. 000000  
 Observed Cond. 000000  
 Obs. Cond. Code  
 Cost Factor 110 110%

SHILOH IL 62221  
 Site Address: 003521 CHIPPEWA DR

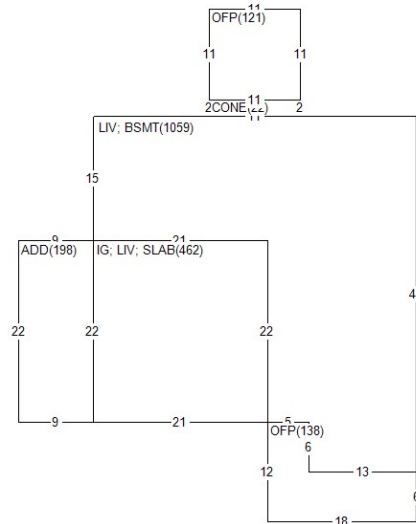

BOOK	PAGE	DATE	QS	SALE PRICE
		0224	Q	435,000
		0523	U	47,000

PERMIT NO	TYPE	DATE	AMOUNT
8298	RS	0523	

Appraiser 040 KK  
 Apr Date 06/21/24  
 Use Code 0040 Imp. Res.  
 NBHD 50005.00 Shiloh Valley  
 L106 M120 B120

AREA	FLAT	EFF%	E/AREA	ACT%	A/AREA	EA/AA	HEATED
LIV	1521	1.00	1521	1.00	1521	1521	1521
BSMT	1059	1.00	1059	1.00	1059	1059	
IG	462	1.00	462	1.00	462	462	
SLAB	462	1.00	462	1.00	462	462	
ADD	198	0.00	0	0.00	0	0	
OFFP	259	1.00	259	1.00	259	259	
CONE	22	1.00	22	1.00	22	22	

History Values

Tax Year	Total Appraised Value
24	298,296
23	1,281
22	1,194

MISC	BLDG CODE	DESC	LENGTH	WIDTH	UNITS	EYB DT
1	1 CP	Concrete Paving	46.00	30.00	1380.00	2024 A
2	1 OFFP	Open Frame Porch	.00	.00	138.00	2024 A
3	1 TMBC	Trim Mas/Brk CD-	.00	.00	100.00	2024 A
4	1 GAMF	Mas/Frm Gar Cnc	21.00	9.00	189.00	2024 A
5	1 OFFP	Open Frame Porch	11.00	11.00	121.00	2024 A
6	1 FB	Finished Basemen	.00	.00	750.00	2024 A

LAND	LUSE	DESC	UNITS	TP	ADJUSTMENT CODES
1	0040	RES- IMP RESIDEN	1.00	L	