

BLDG # 1
 Style (Tb-02) 1.0 One Story
 Quality (Yr-95) C+10 C+10 Averag
 Building Use 0040 Single Fami
 Exterior Wall 1 F Frame
 Exterior Wall 2
 Foundation Adj F Full Bsmt
 Basement
 Combination
 Attic Area
 Heat/AC Adj AC Central Air
 Comb Ht/AC Adj
 Fireplace 03 C-Fireplace
 Extra Fireplace 00 N/A
 Res Fixtures 0014 14 Fixtures
 Garage MF Masonry/Fra
 Mobile Home 0000 N/A
 Design Adj 04 Good
 Actual Year Blt 2022
 Effect Year Blt 2022
 Normal Depr Tbl A Res CDU - A
 Functional Obs. 000000
 Economic Obs. 000000
 Observed Cond. 000000
 Obs. Cond. Code
 Cost Factor 125 125%

SHILOH IL 62221
 Site Address: 003456 DAKOTA DR

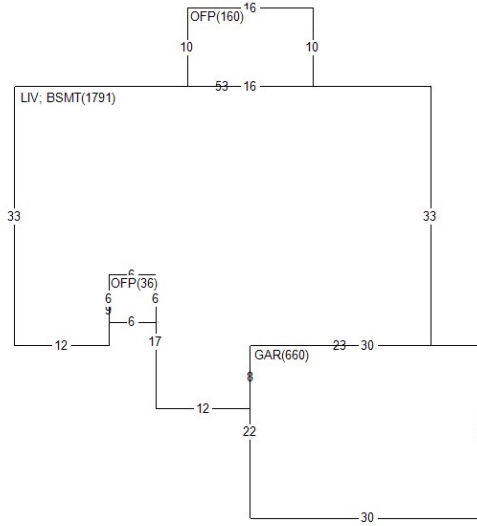

BOOK	PAGE	DATE	QS	SALE PRICE
		0424	Q	422,500
		0722	Q	410,000
		0122	Q	46,500
PERMIT NO	TYPE	DATE		AMOUNT
8020	RS	1221		

Appraiser 040 KK
 Apr Date 08/03/23
 Use Code 0040 Imp. Res.
 NBHD 50005.00 Shiloh Valley
 L106 M120 B120

AREA	FLAT	EFF% E/AREA	ACT% A/AREA	EA/AA	HEATED
LIV	1791	1.00	1791	1.00	1791
BSMT	1791	1.00	1791	1.00	1791
OFP	196	1.00	196	1.00	196
GAR	660	1.00	660	1.00	660

History Values

Tax Year	Total Appraised Value
24	397,329
23	345,804
22	141,750

MISC	BLDG CODE	DESC	LENGTH	WIDTH	UNITS	EYB DT
1	1	TMBC	Trim Mas/Brk CD-	.00	.00	284.00 2022 A
2	1	OFP	Open Frame Porch	10.00	16.00	160.00 2022 A
3	1	OFP	Open Frame Porch	6.00	6.00	36.00 2022 A
4	1	CP	Concrete Paving	30.00	34.00	1020.00 2022 A
5	1	CP	Concrete Paving	41.00	6.00	246.00 2022 A
6	1	FB	Finished Basemen	.00	.00	875.00 2022 A

LAND	LUSE	DESC	UNITS	TP	ADJUSTMENT CODES
1	0040	RES- IMP RESIDEN	1.00	L	

Req By: ANDREA 03/04/26 9:32:33 ST CLAIR CURRENT YEAR 2025
MCKINNEY BRADLEY R & HOWELL DE
3456 DAKOTA DR

SHILOH IL 62221
Site Address: 003456 DAKOTA DR

BOOK PAGE DATE QS SALE PRICE

PERMIT NO TYPE DATE AMOUNT

Appraiser 040 KK
Appr Date 08/03/23
Use Code 0040 Imp. Res.
NBHD 50005.00 L106 M120 B120

History Values

Tax Year	Total Appraised Value
21	1,122
20	1,095
19	1,098

MISC	BLDG CODE	DESC	LENGTH	WIDTH	UNITS	EYB DT
7	1 VCL	Vaulted Ceiling	.00	.00	528.00	2022 A
8	1 FV6'SB	FENCE VYNL 6' SL	.00	.00	170.00	2023 A
9	1 DECK	Deck - Wood	12.00	10.00	120.00	2022 A