

BLDG # 1
 Style (Tb-02) 1.0 One Story
 Quality (Yr-95) C+10 C+10 Averag
 Building Use 0040 Single Fami
 Exterior Wall 1 F Frame
 Exterior Wall 2 F
 Foundation Adj F Full Bsmt
 Basement
 Combination
 Attic Area
 Heat/AC Adj AC Central Air
 Comb Ht/AC Adj
 Fireplace 00 N/A
 Extra Fireplace 00 N/A
 Res Fixtures 0010 10 Fixtures
 Garage F Garage Attd
 Mobile Home 0000 N/A
 Design Adj 04 Good
 Actual Year Blt 2023
 Effect Year Blt 2023
 Normal Depr Tbl A Res CDU - A
 Functional Obs. 000000
 Economic Obs. 000000
 Observed Cond. 000000
 Obs. Cond. Code
 Cost Factor 125 125%

SHILOH IL 62221
 Site Address: 003463 DAKOTA DR

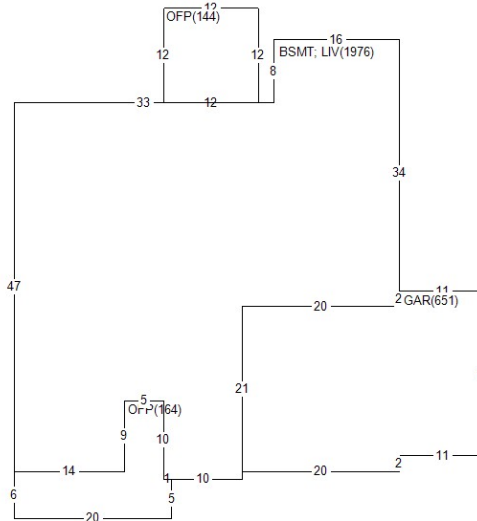

BOOK	PAGE	DATE	QS	SALE PRICE
		0523	Q	452,600
		0422	Q	55,900

PERMIT NO	TYPE	DATE	AMOUNT

Appraiser 040 KK
 Aprr Date 10/18/23
 Use Code 0040 Imp. Res.
 NBHD 50005.00 Shiloh Valley
 L106 M120 B120

AREA	FLAT	EFF% E/AREA	ACT% A/AREA	EA/AA HEATED
OFF	308	1.00	308 1.00	308 308
BSMT	1976	1.00	1976 1.00	1976 1976
LIV	1976	1.00	1976 1.00	1976 1976 1976
GAR	651	1.00	651 1.00	651 651

History Values

Tax Year	Total Appraised Value
24	375,553
23	244,845
22	61,521

MISC	BLDG CODE	DESC	LENGTH	WIDTH	UNITS	EYB DT
1	1	OFFP	Open Frame Porch	.00	.00	169.00 2023 A
2	1	CP	Concrete Paving	38.00	31.00	1178.00 2023 A
3	1	CP	Concrete Paving	15.00	4.00	60.00 2023 A
4	1	OFFP	Open Frame Porch	12.00	12.00	144.00 2023 A
5	1	VCL	Vaulted Ceiling	.00	.00	210.00 2023 A
6	1	ALF	Aluminum Fence	.00	.00	234.00 2023 A

LAND	LUSE	DESC	UNITS	TP	ADJUSTMENT CODES
1	0040	RES- IMP RESIDEN	1.00	L	

Req By: ANDREA 03/04/26 9:32:33 ST CLAIR CURRENT YEAR 2025
KUNG JERRY J & YAO EVELINE F
3463 DAKOTA DR

SHILOH IL 62221
Site Address: 003463 DAKOTA DR

BOOK PAGE DATE QS SALE PRICE

PERMIT NO TYPE DATE AMOUNT

Appraiser 040 KK
Appr Date 10/18/23
Use Code 0040 Imp. Res.
NBHD 50005.00 L106 M120 B120

History Values

Tax Year	Total Appraised Value
21	1,122
20	1,095
19	1,098

MISC BLDG CODE	DESC	LENGTH	WIDTH	UNITS	EYB DT
7 1 TMBC	Trim Mas/Brk CD-	.00	.00	332.00	2023 A