

BELLEVILLE IL 62221
Site Address: 000708 SANTA FE CT

BLDG # 1
Style (Tb-02) 1.0 One Story
Quality (Yr-95) C+10 C+10 Averag
Building Use 0040 Single Fami
Exterior Wall 1 F Frame
Exterior Wall 2
Foundation Adj F Full Bsmt
Basement
Combination
Attic Area
Heat/AC Adj AC Central Air
Comb Ht/AC Adj
Fireplace 03 C-Fireplace
Extra Fireplace 00 N/A
Res Fixtures 0012 12 Fixtures
Garage MF Masonry/Fra
Mobile Home 0000 N/A
Design Adj 04 Good
Actual Year Blt 2019
Effect Year Blt 2019
Normal Depr Tbl A Res CDU - A
Functional Obs. 000000
Economic Obs. 000000
Observed Cond. 000000
Obs. Cond. Code
Cost Factor 000 N/A

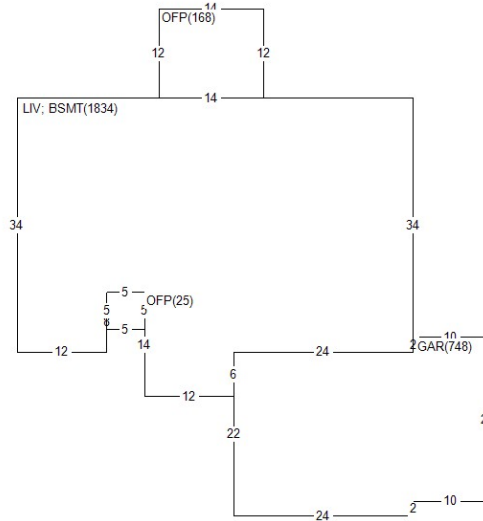

BOOK	PAGE	DATE	QS	SALE PRICE
		1121	Q	362,500
		0819	Q	285,000
		0319	Q	46,750
PERMIT NO	TYPE	DATE		AMOUNT

Appraiser 040 KK
Apr Date 08/04/23
Use Code 0040 Imp. Res.
NBHD 50005.00 Shiloh Valley
L106 M120 B120

AREA	FLAT	EFF% E/AREA	ACT% A/AREA	EA/AA	HEATED
GAR	748	1.00	748	1.00	748
LIV	1834	1.00	1834	1.00	1834
BSMT	1834	1.00	1834	1.00	1834
OFF	193	1.00	193	1.00	193

History Values

Tax Year	Total Appraised Value
24	348,806
23	277,290
22	258,279

MISC	BLDG CODE	DESC	LENGTH	WIDTH	UNITS	EYB DT
1	1	OFF	5.00	5.00	25.00	2019 A
2	1	OFF	12.00	14.00	168.00	2019 A
3	1	CP	46.00	5.00	230.00	2019 A
4	1	CP	.00	.00	1023.00	2019 A
5	1	VCL	.00	.00	360.00	2019 A
6	1	TMBC	.00	.00	186.00	2019 A
LAND	LUSE	DESC	UNITS	TP	----- ADJUSTMENT CODES -----	
1	0040	RES- IMP RESIDEN	1.00	L		

Req By: ANDREA 03/04/26 9:32:33 ST CLAIR CURRENT YEAR 2025
SALANITRI DAVID A & MELANIE J
708 SANTA FE CT

BELLEVILLE IL 62221
Site Address: 000708 SANTA FE CT

BOOK PAGE DATE QS SALE PRICE

PERMIT NO TYPE DATE AMOUNT

Appraiser 040 KK
Appr Date 08/04/23
Use Code 0040 Imp. Res.
NBHD 50005.00 L106 M120 B120

History Values

Tax Year	Total Appraised Value
21	242,880
20	236,817
19	102,684

MISC	BLDG CODE	DESC	LENGTH	WIDTH	UNITS	EYB DT
7	1 FB	Finished Basemen	.00	.00	890.00	2020 A
8	1 X61SB	CIP Fence SolidB	.00	.00	300.00	2021 A