

Req By: ANDREA
MAASSEN DEREK & KYLEE
709 SANTA ANA CT

BLDG # 1
 Style (Tb-02) 1.0 One Story
 Quality (Yr-95) C+10 C+10 Averag
 Building Use 0040 Single Fami
 Exterior Wall 1 F Frame
 Exterior Wall 2
 Foundation Adj F Full Bsmt
 Basement
 Combination
 Attic Area
 Heat/AC Adj AC Central Air
 Comb Ht/AC Adj
 Fireplace 03 C-Fireplace
 Extra Fireplace 00 N/A
 Res Fixtures 0010 10 Fixtures
 Garage F Garage Attd
 Mobile Home 0000 N/A
 Design Adj 00 N/A
 Actual Year Blt 2015
 Effect Year Blt 2015
 Normal Depr Tbl A Res CDU - A
 Functional Obs. 000000
 Economic Obs. 000000
 Observed Cond. 000000
 Obs. Cond. Code
 Cost Factor 000 N/A

BELLEVILLE IL 62221
 Site Address: 000709 SANTA ANNA CT

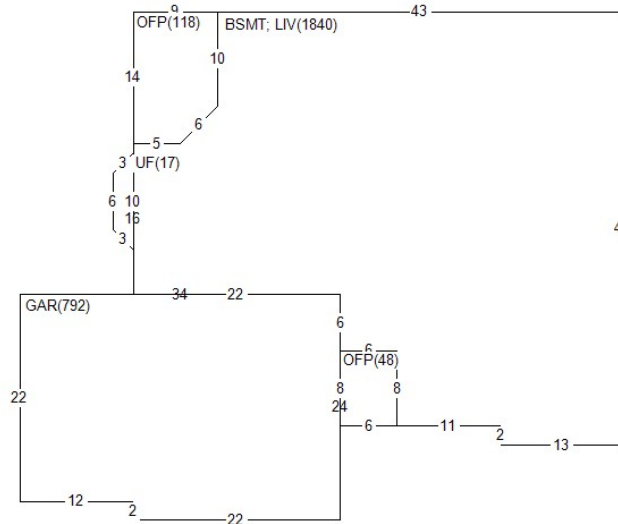

BOOK	PAGE	DATE	QS	SALE PRICE
		0722	Q	385,700
		0622	Q	380,000
		0620	Q	289,000
PERMIT NO	TYPE	DATE	AMOUNT	
5485	RS	0914		

Appraiser 040 KK
 Appr Date 08/04/23
 Use Code 0040 Imp. Res.
 NBHD 50005.00 Shiloh Valley
 L106 M120 B120

AREA	FLAT	EFF% E/AREA	ACT% A/AREA	EA/AA	HEATED
GAR	792	1.00	792	1.00	792
BSMT	1840	1.00	1840	1.00	1840
LIV	1840	1.00	1840	1.00	1840
UF	17	1.00	17	1.00	17
OFF	166	1.00	166	1.00	166

History Values

Tax Year	Total Appraised Value
24	320,918
23	284,271
22	264,783

MISC BLDG CODE	DESC	LENGTH	WIDTH	UNITS	EYB DT
1 1 CP	Concrete Paving	.00	.00	1180.00	2015 A
2 1 OFP	Open Frame Porch	.00	.00	118.00	2015 A
3 1 PTOC	Patio Concrete	14.00	12.00	168.00	2015 A
4 1 TMBC	Trim Mas/Brk CD-	.00	.00	356.00	2015 A
5 1 FB	Finished Basemen	.00	.00	709.00	2015 A
6 1 OFP	Open Frame Porch	.00	.00	48.00	2015 A

LAND LUSE DESC	UNITS TP	ADJUSTMENT CODES
1 0040 RES- IMP RESIDEN	1.00 L	

Req By: ANDREA
MAASSEN DEREK & KYLEE
709 SANTA ANA CT

BELLEVILLE IL 62221
Site Address: 000709 SANTA ANNA CT

BOOK	PAGE	DATE QS	SALE PRICE
		1215 Q	264,900
		1214 Q	45,000

PERMIT NO	TYPE	DATE	AMOUNT

Appraiser 040 KK
 Appr Date 08/04/23
 Use Code 0040 Imp. Res.
 NBHD 50005.00 L106 M120 B120

History Values

Tax Year	Total Appraised Value
21	248,997
20	242,784
19	249,840

MISC	BLDG CODE	DESC	LENGTH	WIDTH	UNITS	EYB DT
7	1 CP	Concrete Paving	6.00	17.00	102.00	2015 A
8	1 X61SB	CIP Fence SolidB	.00	.00	315.00	2016 A
9	1 VCL	Vaulted Ceiling	.00	.00	200.00	2015 A