

Req By: ANDREA
KOBIA MICHAEL P LLC
3502 CHIPPEWA DR

BLDG # 1
 Style (Tb-02) 1.0 One Story
 Quality (Yr-95) C+10 C+10 Averag
 Building Use 0040 Single Fami
 Exterior Wall 1 F Frame
 Exterior Wall 2
 Foundation Adj F Full Bsmt
 Basement
 Combination
 Attic Area
 Heat/AC Adj AC Central Air
 Comb Ht/AC Adj
 Fireplace 00 N/A
 Extra Fireplace 00 N/A
 Res Fixtures 0012 12 Fixtures
 Garage F Garage Attd
 Mobile Home 0000 N/A
 Design Adj 00 N/A
 Actual Year Blt 2022
 Effect Year Blt 2022
 Normal Depr Tbl A Res CDU - A
 Functional Obs. 000000
 Economic Obs. 000000
 Observed Cond. 000000
 Obs. Cond. Code
 Cost Factor 120 120%

SHILOH IL 62221
Site Address: 003502 CHIPPEWA DR

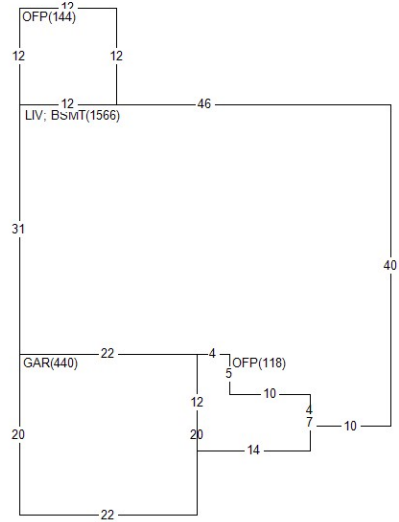

BOOK	PAGE	DATE	QS	SALE PRICE
		0722	Q	374,259
		0222	U	43,500

PERMIT NO	TYPE	DATE	AMOUNT
8080	RS	0322	

Appraiser 003 MJ
 Apr Date 08/01/23
 Use Code 0040 Imp. Res.
 NBHD 50005.00 Shiloh Valley
 L106 M120 B120

AREA	FLAT	EFF%	E/AREA	ACT%	A/AREA	EA/AA	HEATED
LIV	1566	1.00	1566	1.00	1566	1566	1566
BSMT	1566	1.00	1566	1.00	1566	1566	
GAR	440	1.00	440	1.00	440	440	
OFF	262	1.00	262	1.00	262	262	

History Values

Tax Year	Total Appraised Value
24	310,690
23	273,666
22	112,884

MISC	BLDG CODE	DESC	LENGTH	WIDTH	UNITS	EYB	DT
1	1	OFFP	Open Frame Porch	.00	.00	118.00	2022 A
2	1	OFFP	Open Frame Porch	12.00	12.00	144.00	2022 A
3	1	CP	Concrete Paving	35.00	20.00	700.00	2022 A
4	1	CP	Concrete Paving	4.00	16.00	64.00	2022 A
5	1	PATIOCNC	Concrete Patio	12.00	14.00	168.00	2022 A
6	1	FB	Finished Basemen	.00	.00	783.00	2022 A

LAND	LUSE	DESC	UNITS	TP	ADJUSTMENT CODES
1	0040	RES- IMP RESIDEN	1.00	L	

Req By: ANDREA
KOBIA MICHAEL P LLC
3502 CHIPPEWA DR

SHILOH IL 62221
Site Address: 003502 CHIPPEWA DR

BOOK PAGE DATE QS SALE PRICE

PERMIT NO TYPE DATE AMOUNT

Appraiser 003 MJ
Appr Date 08/01/23
Use Code 0040 Imp. Res.
NBHD 50005.00 L106 M120 B120

History Values

Tax Year	Total Appraised Value
21	1,122
20	1,095
19	1,098

MISC	BLDG CODE	DESC	LENGTH	WIDTH	UNITS	EYB DT
7	1	TMBC	Trim Mas/Brk CD-	.00	.00	234.00 2022 A
8	1	VCL	Vaulted Ceiling	.00	.00	362.00 2022 A
9	1	ALF	Aluminum Fence	.00	.00	150.00 2022 A