

Req By: ANDREA  
LOGAN DARRELL & ANGELA  
3426 CHIPPEWA DR

BLDG # 1  
 Style (Tb-02) 1.0 One Story  
 Quality (Yr-95) C+10 C+10 Averag  
 Building Use 0040 Single Fami  
 Exterior Wall 1 F Frame  
 Exterior Wall 2  
 Foundation Adj F Full Bsmt  
 Basement  
 Combination  
 Attic Area  
 Heat/AC Adj AC Central Air  
 Comb Ht/AC Adj  
 Fireplace 03 C-Fireplace  
 Extra Fireplace 00 N/A  
 Res Fixtures 0010 10 Fixtures  
 Garage F Garage Attd  
 Mobile Home 0000 N/A  
 Design Adj 04 Good  
 Actual Year Blt 2021  
 Effect Year Blt 2021  
 Normal Depr Tbl A Res CDU - A  
 Functional Obs. 000000  
 Economic Obs. 000000  
 Observed Cond. 000000  
 Obs. Cond. Code  
 Cost Factor 115 115%

SHILOH IL 62221  
 Site Address: 003426 CHIPPEWA DR

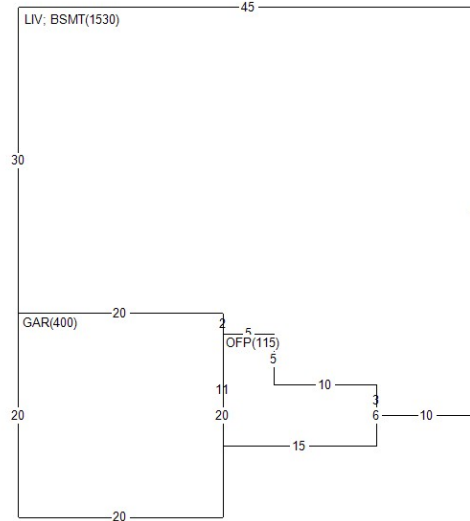

BOOK	PAGE	DATE	QS	SALE PRICE
		0621	Q	300,000
		1120	U	39,900

PERMIT NO	TYPE	DATE	AMOUNT
-----------	------	------	--------

Appraiser 003 MJ  
 Apr Date 08/02/23  
 Use Code 0040 Imp. Res.  
 NBHD 50005.00 Shiloh Valley  
 L106 M120 B120

AREA	FLAT	EFF%	E/AREA	ACT%	A/AREA	EA/AA	HEATED
LIV	1530	1.00	1530	1.00	1530	1530	1530
BSMT	1530	1.00	1530	1.00	1530	1530	
OFFP	115	1.00	115	1.00	115	115	
GAR	400	1.00	400	1.00	400	400	

History Values

Tax Year	Total Appraised Value
24	308,705
23	290,439
22	270,528

MISC	BLDG CODE	DESC	LENGTH	WIDTH	UNITS	EYB DT
1	1 CP	Concrete Paving	34.00	17.00	578.00	2021 A
2	1 CP	Concrete Paving	13.00	4.00	52.00	2021 A
3	1 OFFP	Open Frame Porch	.00	.00	126.00	2021 A
4	1 TMBC	Trim Mas/Brk CD-	.00	.00	140.00	2021 A
5	1 PATIOCNC	Concrete Patio	12.00	12.00	144.00	2021 A
6	1 FB	Finished Basemen	.00	.00	450.00	2021 A

LAND LUSE	DESC	UNITS	TP	ADJUSTMENT CODES
1	0040 RES- IMP RESIDEN	1.00	L	

Req By: ANDREA  
LOGAN DARRELL & ANGELA  
3426 CHIPPEWA DR

SHILOH IL 62221  
Site Address: 003426 CHIPPEWA DR

BOOK PAGE DATE QS SALE PRICE

PERMIT NO TYPE DATE AMOUNT

Appraiser 003 MJ  
Appr Date 08/02/23  
Use Code 0040 Imp. Res.  
NBHD 50005.00 L106 M120 B120

History Values

Tax Year	Total Appraised Value
21	147,189
20	1,095
19	1,098

MISC	BLDG CODE	DESC	LENGTH	WIDTH	UNITS	EYB DT
7	1 VCL	Vaulted Ceiling	.00	.00	512.00	2021 A